



EPL153

Electric Pallet Truck 1.5T

- Smart Lithium Battery;
- Newly Designed Handle Head;
- pass market tests of safety and reliability.



www.scantruck.com.sg
(+65)6305 6600
marketing@scantruck.com.sg

[GET YOUR FREE QUOTE](#)



FEATURE

■ Smart Lithium Battery

EPL153 uses lithium batteries and built-in chargers, so it can be used even when charged. It saves worries about the endurance and there is no need of special charging area.



■ Newly Designed Handle Head

EPL153 is lifted by electricity and lowered manually, there is no need to worry about damaging goods by uncontrollable lowering.



■ Pass Market Tests Of Safety And Reliability

EPL153 has 10-year market-tested components.



Electric Pallet Truck 1.5T

EPL153

Distinguishing mark				
1.1	Manufacturer			EP
1.2	Model designation			EPL153
1.3	Drive unit			Battery
1.4	Operator type			Pedestrian
1.5	rated capacity	Q	kg	1500
1.6	Load center distance	c	mm	600
1.8	Load distance	x	mm	950(880)
1.9	Wheelbase	y	mm	1190(1120)
Weight				
2.1	Service weight (include battery)		kg	115
2.2	Axle loading, laden driving side/loading side		kg	540/1070
2.3	Axle loading, unladen driving side/loading side		kg	100/15
Types,Chassis				
3.1	Tyre type driving wheels/loading wheels			PU
3.2	Tyre size, driving wheels (diameter×width)		mm	Φ210x70
3.3	Tyre size, loading wheels (diameter×width)		mm	Φ210x70
3.4	Tyre size, caster wheels (diameter×width)		mm	Φ80x60(Φ74x88)
3.5	Wheels, number driving, caster/loading (x=drive wheels)		mm	1x/4(1x/2)
3.6	Track width, front,driving side	b10	mm	
3.7	Track width,rear,loading side	b11	mm	
Dimensions				
4.4	Lift height	h3	mm	115
4.9	Height drawbar in driving position min./max.	h14	mm	750/1190
4.15	Lowered height	h13	mm	80
4.19	Overall length	l1	mm	1550
4.20	Length to face of forks	l2	mm	400
4.21	Overall width	b1	mm	560(685)
4.22	Fork dimensions	sxexl	mm	50x150x1150
4.25	Distance between fork-arms	b5	mm	560(685)
4.32	Ground clearance, center of wheelbase	m2	mm	30
4.34.1	Aisle width for pallets 1000 × 1200 crossways	Ast	mm	1650
4.34.2	Aisle width for pallets 800 × 1200 lengthways	Ast	mm	1850
4.35	Turning radius	Wa	mm	1390
Performance data				
5.1	Travel speed, laden/ unladen	km/ h	km/h	4/4.5
5.2	Lifting speed, laden/ unladen		m/ s	0.017/0.024
5.3	Lowering speed, laden/ unladen		m/ s	0.09/0.06
5.8	Max. gradeability, laden/unladen		%	6\16
5.10	Service brake type			electric
Electric-engine				
6.1	Drive motor rating S2 60 min		kW	0.75
6.2	Lift motor rating at S3 15%		kW	0.5
6.3	The maximum allowed size battery		mm	230x260x85
6.4	Battery voltage/nominal capacity K5		V/Ah	24/20
6.5	Battery weight		kg	5
Addition data				
8.1	Type of drive control			DC
10.5	Steering type			mechanical
10.7	Sound pressure level at the driver's ear		dB (A)	<74

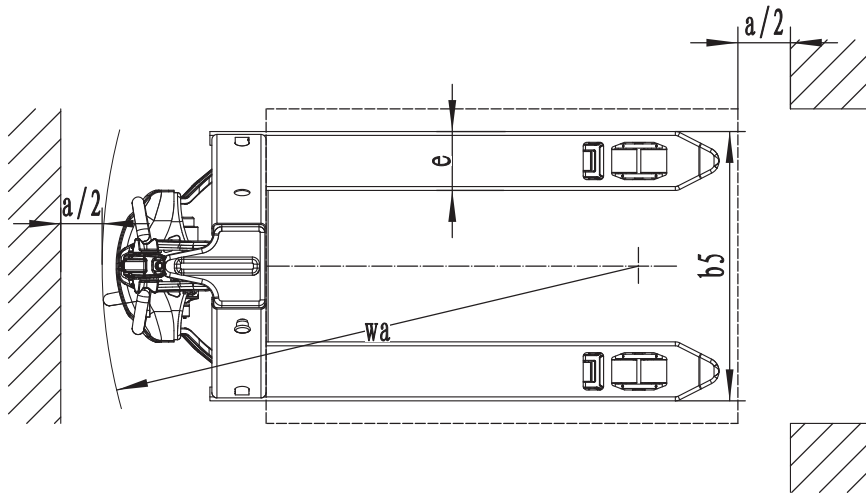
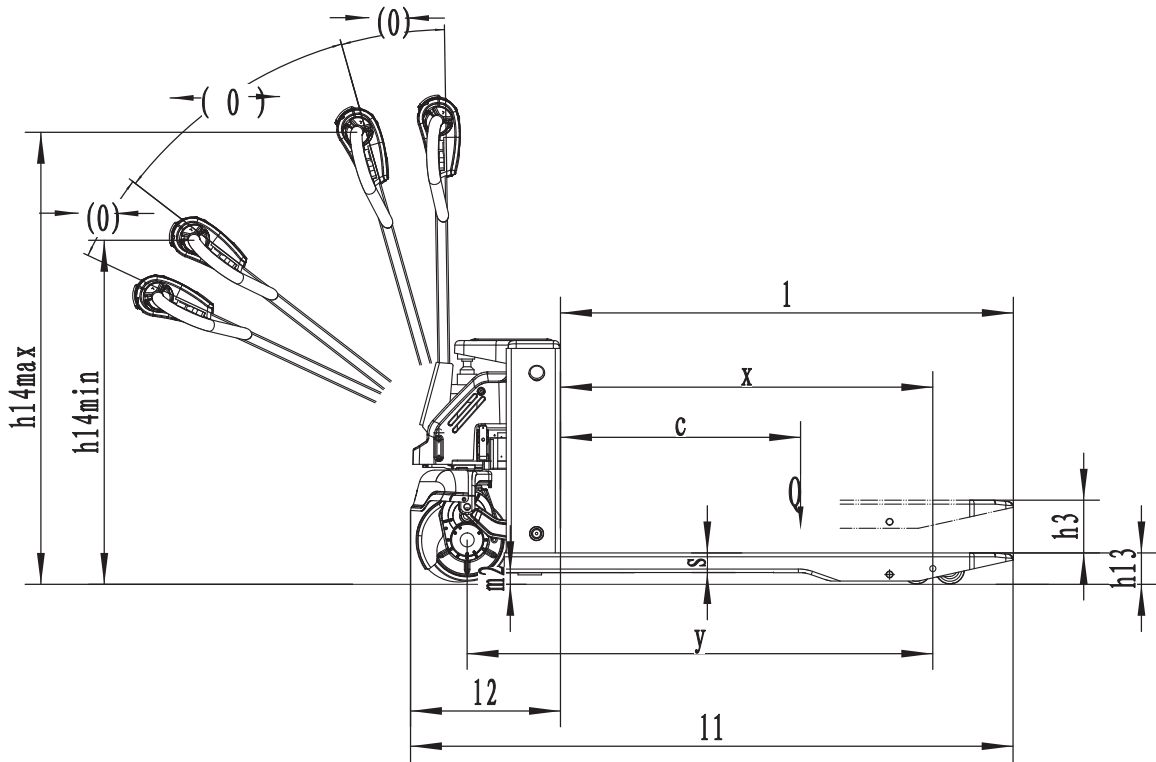

www.Komatsu.com

KOMATSU[®]

SCANTRUCK

GET YOUR FREE QUOTE

www.scantruck.com.sg
 Hotline: (+65)-6305-6600
 Email: marketing@scantruck.com.sg



Materials and specifications are subject to change without notice
KOMATSU is a trademark of Komatsu Ltd. Japan