



## EPT20-30RT/EPT20-30RTS EPT20-35RT/EPT20-35RTS Electric Pallet Truck 3.0/3.5t

Pallet Truck with Higher Speed and Greater Capacity;  
Provides an ideal choice for Super-tough Working Conditions;  
Maximum Capacity Reaches 3.5T and Driving Speed up to 12KM/H;  
Dual Pallet Forks Option Doubles Material Handling Efficiency.



[www.scantruck.com.sg](http://www.scantruck.com.sg)

(+65)6305 6600

[marketing@scantruck.com.sg](mailto:marketing@scantruck.com.sg)

[GET YOUR FREE QUOTE](#)



## FEATURE



### Performance

- The innovative AC system offers strong power, accurate control, excellent performance.
- High strength vertical gearbox, longer working life.
- Low-noise but durable hydraulic unit, good quality cylinder as well as hose ensure the high reliability of hydraulic system.
- AMP connector and durable electric wires greatly reduce malfunctions of components.
- Super high intensity frame design supports high speed, high capacity and long distance applications.
- Adjustable long push rod ensures the stability and lifespan of the truck.

### Safety

- Moving parts are far from operator to avoid accidents.
- Operator can freely switch between high speed/low speed switch, by which safety and reliability are greatly enhanced.
- Dual protection arm can assure the operator to be protected in any standing position.
- Emergency reverse belly button protects operator from getting hurt.
- Emergency disconnecter will cut off power source to avoid accident when truck goes out of control.
- Large pedal allows operator to stand fully inside and well-protected.
- Anti-rolling back brake keeps the truck from skidding down when truck is out of control or travelling on ramp.
- Dual-monitoring power steering, the top safety design (electric steering).

### Operation

- With the new design of ergonomical tiller head, all buttons can be reached conveniently & comfortably.
- Thanks to the entry roller design, this truck enters and exits pallets easily.
- With the design of ergonomical tiller and buttons, the truck can be operated safely and comfortably under various applications with excellent working view.
- High speed wheel are chosen as standard configuration.
- Can be functional as low level order picker with coast control option.
- Side&top open battery compartment allows various battery option, convenient for replacement and maintenance.
- Electric power steering, smooth & comfortable (EPS).

### Maintenance

- AC traction motor, maintenance free.
- Hour meter and battery indicator remind operator of battery charging.
- Easily remove the back cover by only losing four bolts; Access to all key components for inspection, maintenance and replacement.
- Vertical motor makes the inspection & service much more convenient.
- Control system allows easy trouble-shooting.
- Low voltage lift cut off design protects the battery.



# Electric Pallet Truck 3.0t EPT20-30RT/EPT20-30RTS

Distinguishing mark	1.1	Manufacturer			EP	EP
	1.2	Model designation			EPT20-30RT	EPT20-30RTS
	1.3	Drive			Electric	Electric
	1.4	Operator type			Standing	Standing
	1.5	Load capacity	Q	kg	3000	3000
	1.6	Load center distance	c	mm	600	600
	1.8	Load distance, centre of drive axle to fork	x	mm	1042	1042
	1.9	Wheelbase	y	mm	1722	1722
	Service weight	2.1	Service weight		kg	850
2.2		Axle loading, laden front/rear		kg	1110/2740	1110/2740
2.3		Axle loading, unladen front/rear		kg	630/220	630/220
Tyres/chassis	3.1	Tyre type			Polyurethane	Polyurethane
	3.2	Tyre size, front		mm	Φ82.5x165	Φ82.5x165
	3.3	Tyre size, rear		mm	Φ254x95	Φ254x95
	3.4	Additional wheels (castor wheels)		mm	Φ100x63.5	Φ100x63.5
	3.5	Wheels, number front/rear (x=drive wheels)		mm	1x+2/2	1x+2/2
	3.6	Tread width, front	b10	mm	668	668
	3.7	Tread width, rear	b11	mm	456	456
Dimensions	4.4	Lift height	h3	mm	140	140
	4.9	Height of tiller handle in drive position min./max.	h14	mm	970/1602	970/1602
	4.15	Lowered height	h13	mm	82.5	82.5
	4.19	Overall length	l1	mm	2325	2325
	4.20	Length to face of forks	l2	mm	1140	1140
	4.21	Overall width	b1/b2	mm	915	915
	4.22	Fork dimensions	s/e/l	mm	56/230/1190	56/230/1190
	4.25	Distance between fork-arms	b5	mm	686	686
	4.32	Ground clearance, center of wheelbase	m2	mm	26.5	26.5
	4.34.1	Aisle width for pallets 1000×1200 crossways	Ast	mm	2984	2984
	4.34.2	Aisle width for pallets 800×1200 crossways	Ast	mm	2812	2812
4.35	Turning radius	Wa	mm	2182	2182	
Performance data	5.1	Travel speed, laden/unladen		km/h	10.5/12	10.5/12
	5.2	Lifting speed, laden/unladen		m/s	0.03/0.033	0.03/0.033
	5.3	Lowering speed, laden/unladen		m/s	0.040/0.038	0.040/0.038
	5.8	Max. gradeability, laden/unladen		%	8/16	8/16
	5.10	Service brake			Electromagnetic	Electromagnetic
Electric-engine	6.1	Drive motor rating S2 60 min		kW	3.3	3.3
	6.2	Lift motor rating at S3 15%		kW	2.2	2.2
	6.4	Battery voltage/nominal capacity		V/Ah	24/280	24/280
	6.5	Battery weight		kg	250	250
Addition data	8.1	Type of drive control			AC	AC
	10.5	Steering design			Mechanical	Electronic
	10.7	Sound pressure level at the driver's ear		dB(A)	74	74

If there are improvements of technical parameters or configurations, no further notice will be given.  
The diagram shown may contain non-standard configurations.

# Electric Pallet Truck 3.5t

## EPT20-35RT/EPT20-35RTS

Distinguishing mark	1.1	Manufacturer			EP	EP
	1.2	Model designation			EPT20-35RT	EPT20-35RTS
	1.3	Drive			Electric	Electric
	1.4	Operator type			Standing	Standing
	1.5	Load capacity	Q	kg	3500	3500
	1.6	Load center distance	c	mm	600	600
	1.8	Load distance, centre of drive axle to fork	x	mm	1042	1042
	1.9	Wheelbase	y	mm	1722	1722
	Service weight	2.1	Service weight		kg	920
2.2		Axle loading, laden front/rear		kg	1260/3160	1260/3160
2.3		Axle loading, unladen front/rear		kg	690/230	690/230
Tyres/chassis	3.1	Tyre type			Polyurethane	Polyurethane
	3.2	Tyre size, front		mm	Φ82.5x165	Φ82.5x165
	3.3	Tyre size, rear		mm	Φ254x95	Φ254x95
	3.4	Additional wheels (castor wheels)		mm	Φ100x63.5	Φ100x63.5
	3.5	Wheels, number front/rear (x=drive wheels)		mm	1x+2/2	1x+2/2
	3.6	Tread width, front	b10	mm	668	668
	3.7	Tread width, rear	b11	mm	456	456
Dimensions	4.4	Lift height	h3	mm	140	140
	4.9	Height of tiller handle in drive position min./max.	h14	mm	970/1602	970/1602
	4.15	Lowered height	h13	mm	82.5	82.5
	4.19	Overall length	l1	mm	2325	2325
	4.20	Length to face of forks	l2	mm	1140	1140
	4.21	Overall width	b1/b2	mm	915	915
	4.22	Fork dimensions	s/e/l	mm	56/230/1190	56/230/1190
	4.25	Distance between fork-arms	b5	mm	686	686
	4.32	Ground clearance, center of wheelbase	m2	mm	26.5	26.5
	4.34.1	Aisle width for pallets 1000×1200 crossways	Ast	mm	2984	2984
	4.34.2	Aisle width for pallets 800×1200 crossways	Ast	mm	2812	2812
4.35	Turning radius	Wa	mm	2182	2182	
Performance data	5.1	Travel speed, laden/unladen		km/h	10.5/12	10.5/12
	5.2	Lifting speed, laden/unladen		m/s	0.03/0.033	0.028/0.033
	5.3	Lowering speed, laden/unladen		m/s	0.040/0.038	0.040/0.038
	5.8	Max. gradeability, laden/unladen		%	8/16	6/16
	5.10	Service brake			Electromagnetic	Electromagnetic
Electric-engine	6.1	Drive motor rating S2 60 min		kW	3.3	3.3
	6.2	Lift motor rating at S3 15%		kW	2..2	2..2
	6.4	Battery voltage/nominal capacity		V/Ah	24/360	24/360
	6.5	Battery weight		kg	320	320
	Addition data	8.1	Type of drive control			AC
10.5		Steering design			Mechanical	Electronic
10.7		Sound pressure level at the driver's ear		dB(A)	74	74

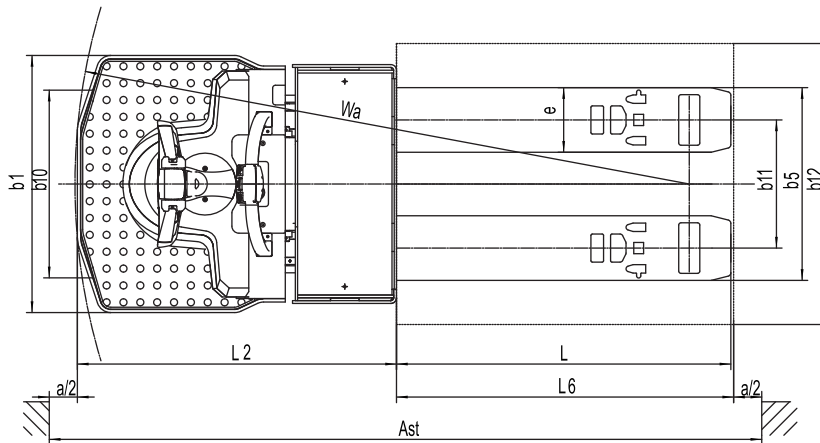
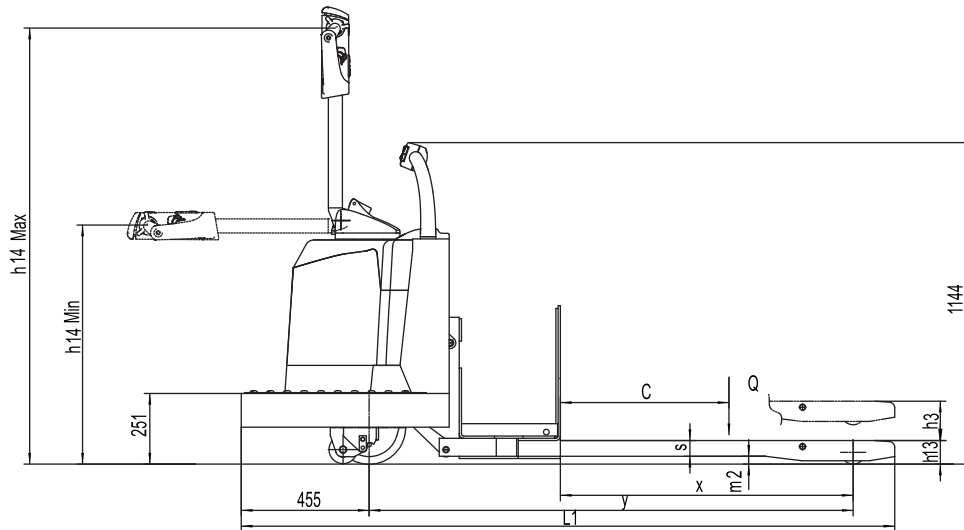

## Option

No.	Optional items	EPT20-30RT(S)/EPT20-35RT(S)
1.1	Fork length	●1190○915/1060/1370/1525/1676/1828 /2134/2362/2428
1.2	Fork width	●686 (< 2000mm) ○710 (> 2000mm)
1.3	Fork lowered height	85
1.4	Fork carriage width	915
1.5	Fork carriage height	○1220mm (48in) ○1520mm (60in)
2.1	Load wheel type	●Single
2.2	Load wheel material	●PU
2.3	Drive wheel material	●PU○Trace PU○Rubber
2.7	Battery capacity	●280Ah○360Ah
2.8	Charger	●24V-30AExternal (280AhBattery) ○24V-50AExternal (360AhBattery)
2.9	Battery indicator	●With time
3.3	Castor wheels	●Yes (other) ○NO (WRT60) - (WPT60)
3.4	Water auto-filling system	○Water auto-filling system
4.1	Battery side pull function	●Battery side pull function

Note: ●Standard ○ Optional - Inconformity